



HEIDENHAIN

Montageanleitung
Mounting Instructions
Instructions de montage
Istruzioni di montaggio
Instrucciones de montaje

TL Micro TL Nano

Lasersysteme
Laser Systems
Systèmes laser
Sistemi laser
Sistemas láser

5/2006



Klasse 2: VDE 0837-IEC 60 825-1
Class 2: VDE 0837-IEC 60 825-1
Classe 2: VDE 0837-IEC 60 825-1
Clase 2: VDE 0837-IEC 60 825-1

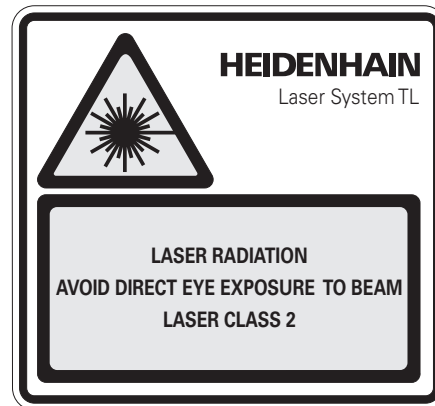

Achtung:

Laserwarnschild (Lieferumfang) gut sichtbar an der Maschine anbringen!

Caution:

Apply the laser warning label (included in delivery) at a well visible location on the machine!

Attention:

Apposer l'étiquette d'avertissement (fourniture) sur un endroit bien visible de la machine!

Attenzione:

applicare la targhetta di avvertenza relativa al laser (inclusa nello standard di fornitura) in posizione ben visibile sulla macchina.

Atención:

¡Colocar en la máquina de forma visible la etiqueta de aviso del láser (suministrada con el aparato)!

TL Micro 150/200/300
TL Nano

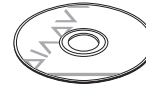

TL Software, Dokumentation
TL software, documentation
Logiciel TL, documentation
Software TL, documentazione
Software TL, documentación

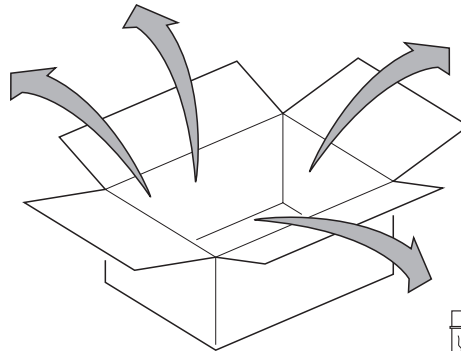
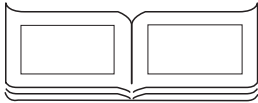

Kleinteile (Laserschild usw.)
Small parts (laser label, etc.)
Petites fournitures (étiquette laser, etc.)
Minuteria (targhetta laser ecc.)
Piezas pequeñas (etiqueta del láser, etc.)

TL Micro 150/200/300

mm



Tolerancing ISO 8015
ISO 2768 - m H
< 6 mm: ±0.2 mm

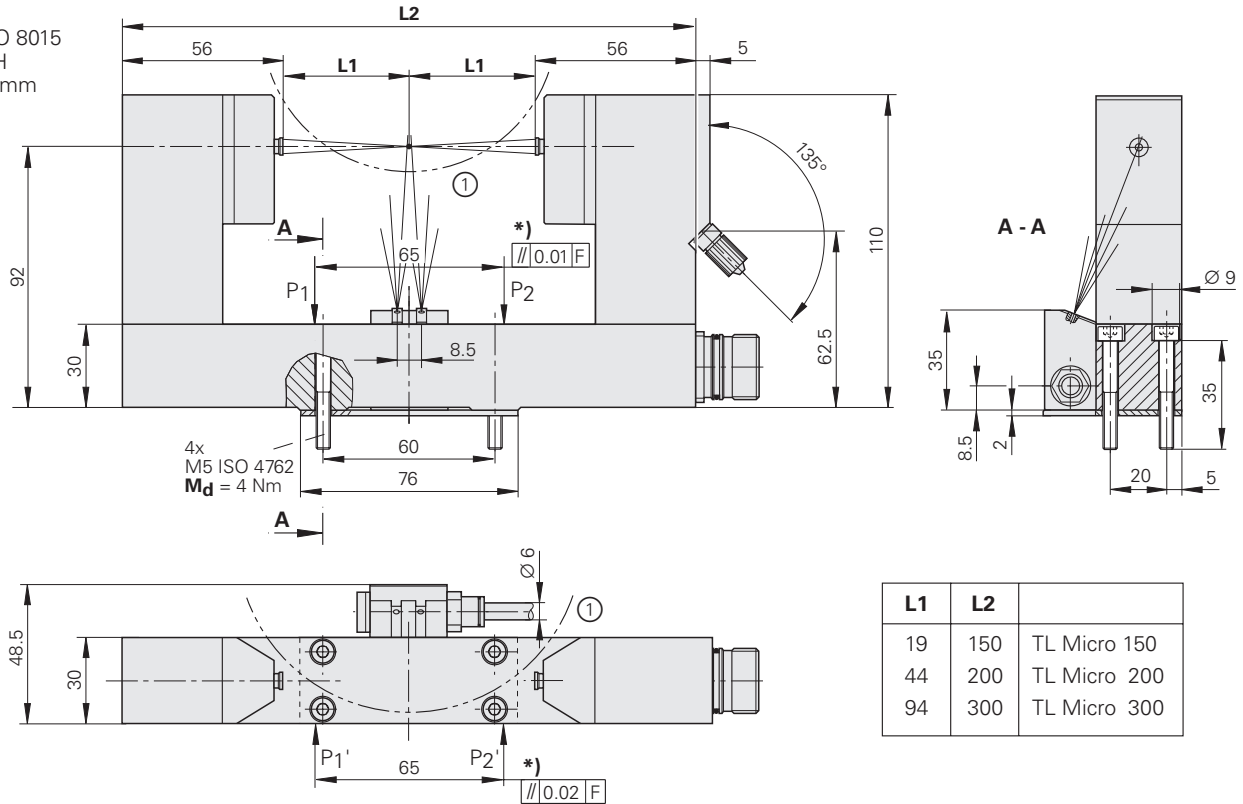

① = Messung des Werkzeugdurchmessers tangential von oben oder seitlich
Measurement of the tool diameter tangentially from above or laterally
Mesure du diamètre de l'outil tangentiellement à partir du haut ou latéralement
Misurazione del diametro utensile tangenzialmente dall'alto o lateralmente
Medición del diámetro de la herramienta tangencialmente desde arriba o desde el lado

Ⓜ2 = Messposition Trägermitte < ±0.5 mm
Measuring position at midpoint of carrier < ±0.5 mm
Position de mesure au centre du support < ±0.5 mm
Posizione di misura al centro del supporto < ±0.5 mm
Posición de medición en el centro del soporte < ±0.5 mm

*) = Ausrichtung Gehäuse
Alignment of housing
Alignement du boîtier
Allineamento dello chassis
Alineación de la carcasa

F = Maschinenführung
Machine guideway
Guidage de la machine
Guida della macchina
Guía de la máquina

P = Messpunkte zum Ausrichten
Measuring points for alignment
Points de mesure pour dégauchissage
Punti di misura per allineamento
Puntos medición alineamiento

Ⓟ = Pneumatik-Anschlüsse
Pneumatic connections
 Raccordements pneumatiques
 Attacchi pneumatici
 Conexiones neumáticas

Ⓟ
 Verschlusskolben
Sealing plug
 Piston de verrouillage
 Pistone di chiusura
 Pistón de cierre

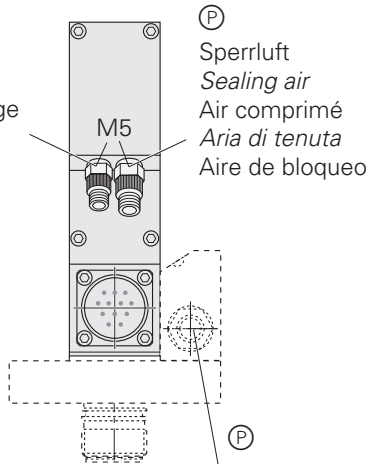

Ⓟ
 Sperrluft
Sealing air
 Air comprimé
 Aria di tenuta
 Aire de bloqueo

Ⓟ
 Abblasvorrichtung
Blower
 Dispositif de soufflage
 Dispositivo di soffiaggio
 Dispositivo de soplado

Empfänger R
Receiver R
 Récepteur R
Ricevente R
 Receptor R

Sender T
Transmitter T
 Emetteur T
Trasmittente T
 Emisor T

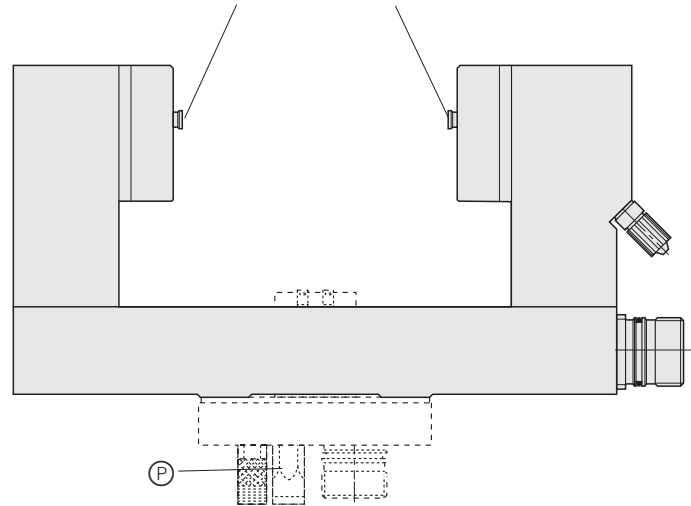

Ⓟ = Pneumatik-Anschlüsse
Pneumatic connections
 Raccordements pneumatiques
 Attacchi pneumatici
 Conexiones neumáticas

Empfänger R Sender T
Receiver R *Transmitter T*
 Récepteur R Émetteur T
Ricevente R *Trasmittente T*
 Receptor R Emisor T

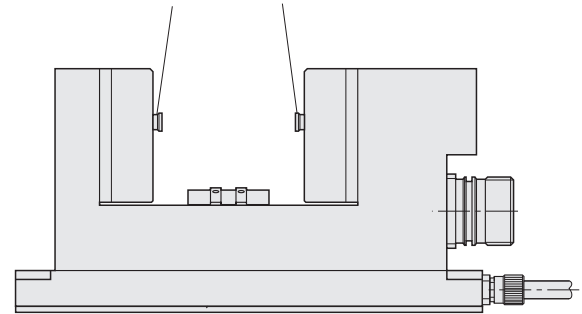
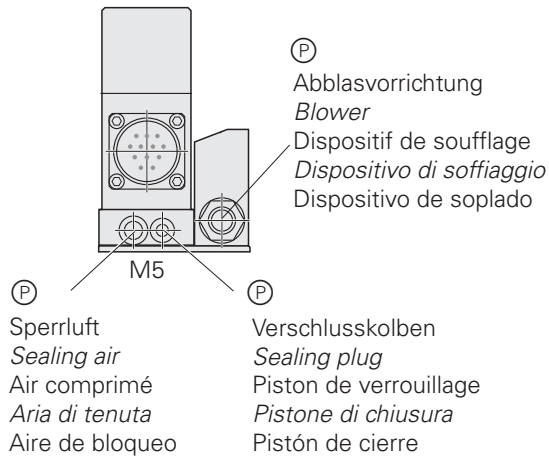

DA 301 TL

Druckluftanlage
 Compressed air unit
 Unité de pressurisation
 Impianto di pressurizzazione
 Sistema de aire comprimido



Id.-Nr. 560 030-01

Verbindungskabel
 Connecting cable
 Câble de liaison
 Cavo di collegamento
 Cable de conexión

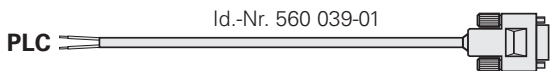
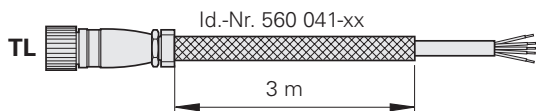
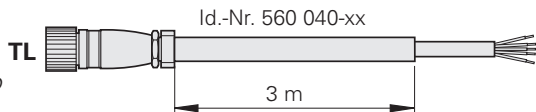

PLC

PLC

TNC
(X13)

Referenzwerkzeug zur Kalibrierung
 Reference tool for calibration
 Etalon pour calibration
 Utensile di riferimento per calibrazione
 Herramienta de referencia para la calibración
 Id.-Nr. 560 032-01

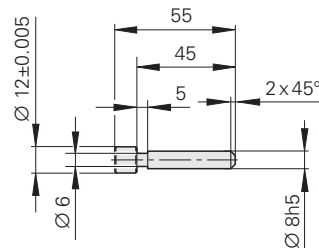

Zubehör optional · *Optional accessories* · Accessoires · *Accessori opzionali* · Accesorios opcionales

Wartungssatz
Maintenance kit
Kit de maintenance
Set di manutenzione
Juego de mantenimiento
Id.-Nr. 560 034-01

Fett
Fat
Graisse
Grasso
Engrasante

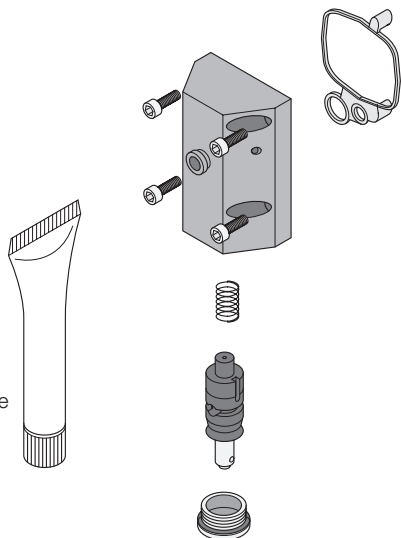

Befestigungsplatte für TL Micro
Fastening plate for TL Micro
Points de fixation pour TL Micro
Piastra di fissaggio per TL Micro
Pletina de sujeción para el TL Micro
Id.-Nr. 560 02801

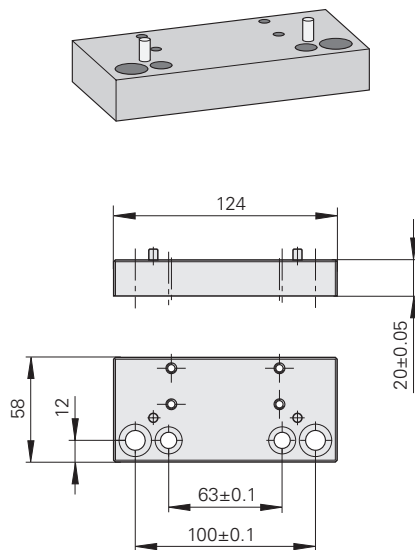

- A** Mechanische Installation TL
Mechanical installation TL
 Installation mécanique TL
Installazione meccanica TL
 Instalación mecánica TL

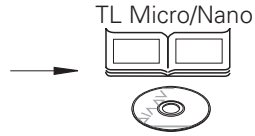

- B** Installation der Pneumatikeinheit DA 301TL
Installation of the DA 301TL compressed air unit
 Installation de l'unité de pressurisation DA 301TL
Installazione dell'unità pneumatica DA 301 TL
 Instalación de la unidad neumática DA 301 TL

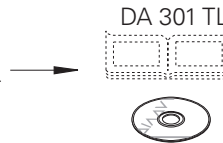

- C** Elektrische Installation
Electrical installation
 Installation électrique
Installazione elettrica
 Instalación eléctrica

- D** Installation der Messzyklen
Installation of measuring cycles
 Installation des cycles de mesure
Installazione dei cicli di misura
 Instalación de los ciclos de medida



- E** Kalibrieren
Calibration
 Calibration
Calibrazione
 Calibración

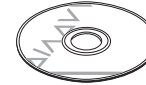

CD

- Installation Manual Measuring Cycles
 - German: PDF
 - English: PDF

- Measuring Cycles
 - TNC 426_430: Zip
 - iTNC 530: Zip

- Programming Manual Measuring Cycles
 - Czech: PDF
 - Danish: PDF
 - Dutch: PDF
 - English: PDF
 - French: PDF
 - German: PDF
 - Italian: PDF
 - Portuguese: PDF
 - Polish: PDF
 - Spanish: PDF

A.1

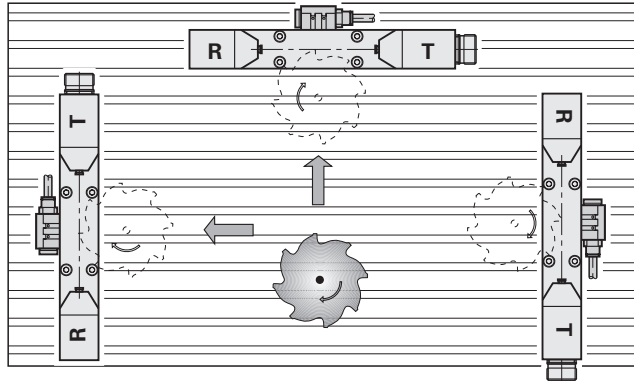

Orientierung zu den Achsen und zur Spindel. Vollständiges Durchfahren des Laserstrahls muss mit dem größten Werkzeug möglich sein. Sender und Empfänger lagestabil und vibrationsfrei an der Maschinenstruktur befestigen.

Vor Kühlmittel und Späneflug schützen sowie die Leitungen geschützt im Befestigungsflansch verlegen.

Orient to the axes and spindle. Ensure complete freedom of travel with the largest tool.

Fasten the transmitter and receiver to the machine structure to ensure position stability and freedom from vibration.

Protect from coolant and flying chips, and configure the cable in the protecting mounting flange.

Orientation par rapport aux axes et à la broche. Le passage complet du faisceau laser doit être possible avec l'outil le plus important.

Fixer l'émetteur et le récepteur de manière stable et sans vibrations sur la structure de la machine.

Assurer une protection contre le liquide de refroidissement et les projections de copeaux et disposer les conducteurs dans la bride de fixation en les protégeant.

Orientamento agli assi e al mandrino. Possibilità di attraversamento completo del raggio laser con l'utensile di maggiori dimensioni.

Fissare trasmittente e ricevente in posizione stabile e priva di vibrazioni sulla struttura della macchina.

Proteggere da refrigerante e trucioli nonché posare i cavi in posizione sicura nella flangia di fissaggio.

Orientación respecto de los ejes y del cabezal. Debe ser posible cruzar de forma completa el rayo láser con la mayor de las herramientas.

Fijar el emisor y el receptor de forma estable y libre de vibraciones a la estructura de la máquina.

Proteger del refrigerante y virutas, e instalar los cables de forma protegida dentro del cono de sujeción.

A.2

Option TL Micro mit seitlichem Kabelausgang:
Montage mit Befestigungsplatte

*Option for TL Micro with lateral cable outlet:
Fastening plate for mounting*

Option TL avec sortie de câble latérale:
Montage avec plaque de fixation

*Opzione TL Micro con uscita cavo laterale:
montaggio con piastra di fissaggio*

Opción TL Micro con salida de cable lateral:
Montaje con pletina de sujeción

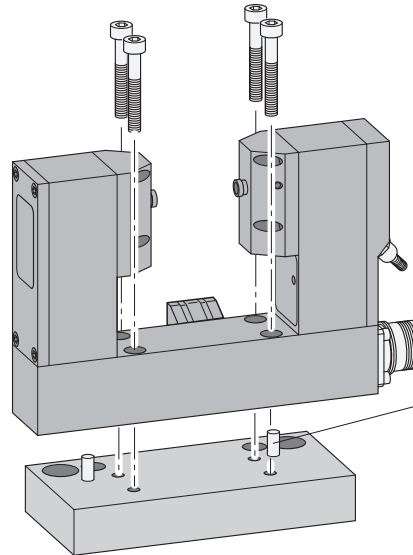

Auf Anschlag der
Pass-Stifte achten!

*Ensure that the locating pins
are completely inserted!*

Attention à la butée
des goujons d'assemblage!

*Prestare attenzione alla
battuta dei perni!*

¡Observar el tope del
pasador de ajuste!!

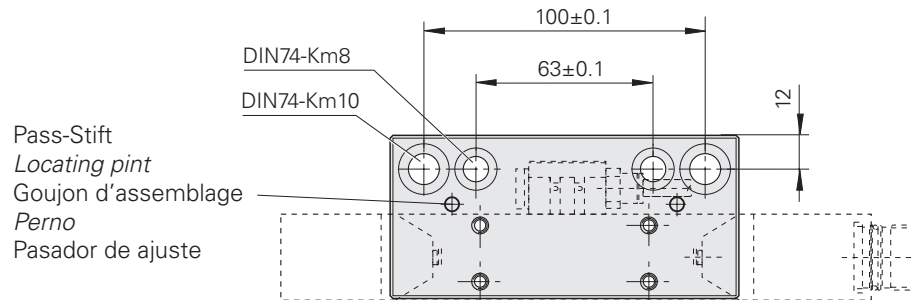

B



Montageanleitung DA 301TL beachten!
Refer to the Mounting Instructions for the DA 301TL!
Consulter les Instructions de montage DA 301TL!
Attenersi alle istruzioni di montaggio DA 301TL!
¡Prestar atención a las instrucciones de montaje del DA 301TL!





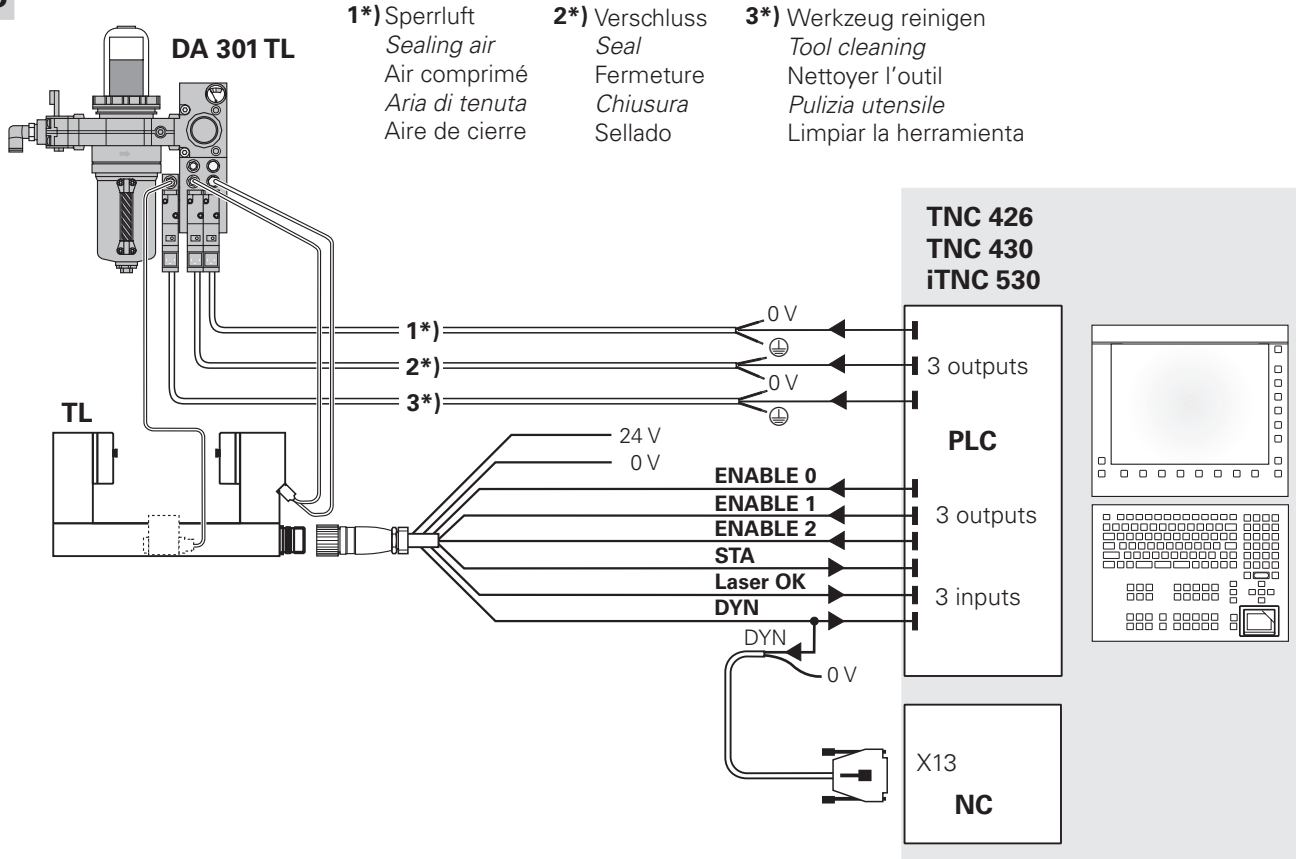

Vorhandene Schraubverschlüsse dürfen nicht gegen Schnellverschlüsse ausgetauscht werden!
Existing screw caps must not be replaced by quick-release fasteners!
Les raccords à vis existants ne doivent pas être remplacés par des raccords rapides!
I tappi a vite presenti non devono essere sostituiti con tappi a chiusura rapida.
¡Los racores existentes no pueden ser sustituidos por racores de enchufe rápido!

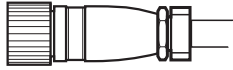
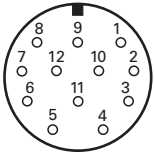

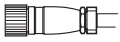
C





	2	1	4	12	6	3	5	7
	Up 24 V	0V	ENABLE 0	ENABLE 1	ENABLE 2	DYN	STA	Laser OK
	br BN	ws WH	ge YL	rs PK	vio VI	gn GN	gr GY	bl BL

PLC – TNC (X13)	Input	
	DYN	0V
	 br BN	 ws WH

Schaltventile zur DA 301 TL Switchover valve to DA 301 TL Valves de commande vers DA 301 TL Valvole di comando per DA 301 TL Electroválvulas para el DA 301 TL	Output		
	1)	0V	2)
	 sw BK	 sw BK	 gegn YL/GN

1) Schaltsignal
 Switching signal
 Signal de commutation
 Segnale di comando
 Señal de contacto

2) Schutzleiter
 Ground
 Conducteur terre
 Conduttore di protezione
 Conexión a tierra



Bei Verwendung einer PLC-Leistungsplatine (PLC 5xx) sind evtl. Leistungswiderstände notwendig.
Siehe CD: "Installation Manual Measuring Cycles", Kap. 2.3.

*Power resistors may be required if a PLC Input/output unit (PLC 5xx) is used.
See CD: "Installation Manual Measuring Cycles", chapter 2.3.*

En cas d'utilisation d'une platine de puissance automate (PLC 5xx), des résistances de puissance peuvent s'avérer nécessaires;
Cf. CD: „Installation Manual Measuring Cycles“, chap. 2.3.

*In caso di impiego di una scheda PLC (PLC 5xx) sono necessarie eventuali resistenze di potenza,
vedi anche cap. 2.3 delle "Installation Manual Measuring Cycles", su CD.*

Al utilizar una pletina de autómatas PLC (PLC 5xx) son necesarias eventualmente resistencias de potencia.
Ver CD: "Installation Manual Measuring Cycles", cap. 2.3.

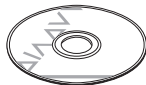

CD

— Installation Manual Measuring Cycles

├ German: PDF

└ English: PDF

D

Siehe CD: "Installation Manual Measuring Cycles", Kap. 3
See CD: "Installation Manual Measuring Cycles," chapter 3
Cf. CD: „Installation Manual Measuring Cycles“, chap. 3
Vedi CD: "Installation Manual Measuring Cycles", cap. 3
Ver CD: "Installation Manual Measuring Cycles", cap. 3

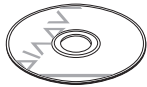

CD

- Installation Manual Measuring Cycles
 - German: PDF
 - English: PDF
- Measuring Cycles
 - TNC 426_430
 - iTNC 530

E  Unter folgenden Umständen muss das Lasermess-System neu kalibriert werden:

- nach einer Inbetriebnahme, Reinigung oder Justage der Lasermess-Systems
- direkt vor präzisen Messungen

The laser measuring system must be recalibrated under the following circumstances:

- *After initial servicing, cleaning or adjustment*
- *Immediately before precision measurements*

Le système de mesure laser doit être recalibré dans les circonstances suivantes:

- après mise en route, nettoyage ou réglage du système de mesure laser
- directement avant d'effectuer des mesures précises

Il sistema di misura laser deve essere ricalibrato in presenza delle seguenti condizioni:

- *dopo una messa in funzione, pulizia o taratura del sistema di misura laser,*
- *direttamente prima di misurazioni precise.*

Bajo las siguientes circunstancias debe calibrarse de nuevo el sistema de medición láser:

- después de una puesta en marcha, limpieza o ajuste del sistema de medición láser
- directamente antes de mediciones precisas

Siehe CD: "Programming Manual Measuring Cycles

See CD: "Programming Manual Measuring Cycles

Cf. CD: „Programming Manual Measuring Cycles

Vedi CD: "Programming Manual Measuring Cycles

Ver CD: "Programming Manual Measuring Cycles

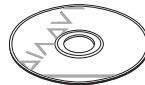

CD

— Programming Manual Measuring Cycles

— Czech: PDF

— Danish: PDF

— Dutch: PDF

— English: PDF

— French: PDF

— German: PDF

— Italian: PDF

— Portuguese: PDF

— Polish: PDF

— Spanish: PDF



U_p = 24 V

(max. 160 mA)



EN 50 178/4.98; 5.2.9.5
IEC 364-4-41: 1992; 411(PELV/SELV)

(siehe, see, voir, vedi, véase
HEIDENHAIN D 231 929)

Eingangssignale

Rechteck-Signale 24 V-

- Freigabe Sender ENABLE 0
- Freigabe 1 Empfänger ENABLE 1
- Freigabe 2 Empfänger ENABLE 2

Ausgangssignale

Rechteck-Signale 24 V-

- Schaltsignal dynamisch DYN
- Schaltsignal statisch STA
- Laser in Ordnung LASER OK

Segnali in ingresso

Segnali a onda quadra 24 V-

- Abilitazione trasmittente ENABLE 0
- Abilitazione 1 ricevente ENABLE 1
- Abilitazione 2 ricevente ENABLE 2

Segnali in uscita

Segnali a onda quadra 24 V-

- Segnale di comando dinamico DYN
- Segnale di comando statico STA
- Laser in perfette condizioni LASER OK

Input signals

Square-wave signals 24 Vdc

- Transmitter release ENABLE 0
- Receiver release 1 ENABLE 1
- Receiver release 2 ENABLE 2

Output signals

Square-wave signals 24 Vdc

- Dynamic switch signal DYN
- Static switch signal STA
- Laser functions OK LASER OK

Señales de entrada

Señales cuadradas 24 V-

- Liberación emisor ENABLE 0
- Liberación 1 receptor ENABLE 1
- Liberación 2 receptor ENABLE 2

Señales de salida

Señales cuadradas 24 V-

- Señal de conmutación dinámica DYN
- Señal de conmutación estática STA
- Láser en correcto funcionamiento LASER OK

Signaux en entrée

Signaux rectangulaires 24V-

- Activation émetteur ENABLE 0
- Activation 1 récepteur ENABLE 1
- Activation 2 récepteur ENABLE 2

Signaux de sortie

Signaux rectangulaires 24V-

- Signal de commutation dynamique DYN
- Signal de commutation statique STA
- Laser en service LASER OK

Statusanzeigen LED · LED status displays · Affichages d'état LED · Indicatori di stato LED · LED de visualizaciones de estado

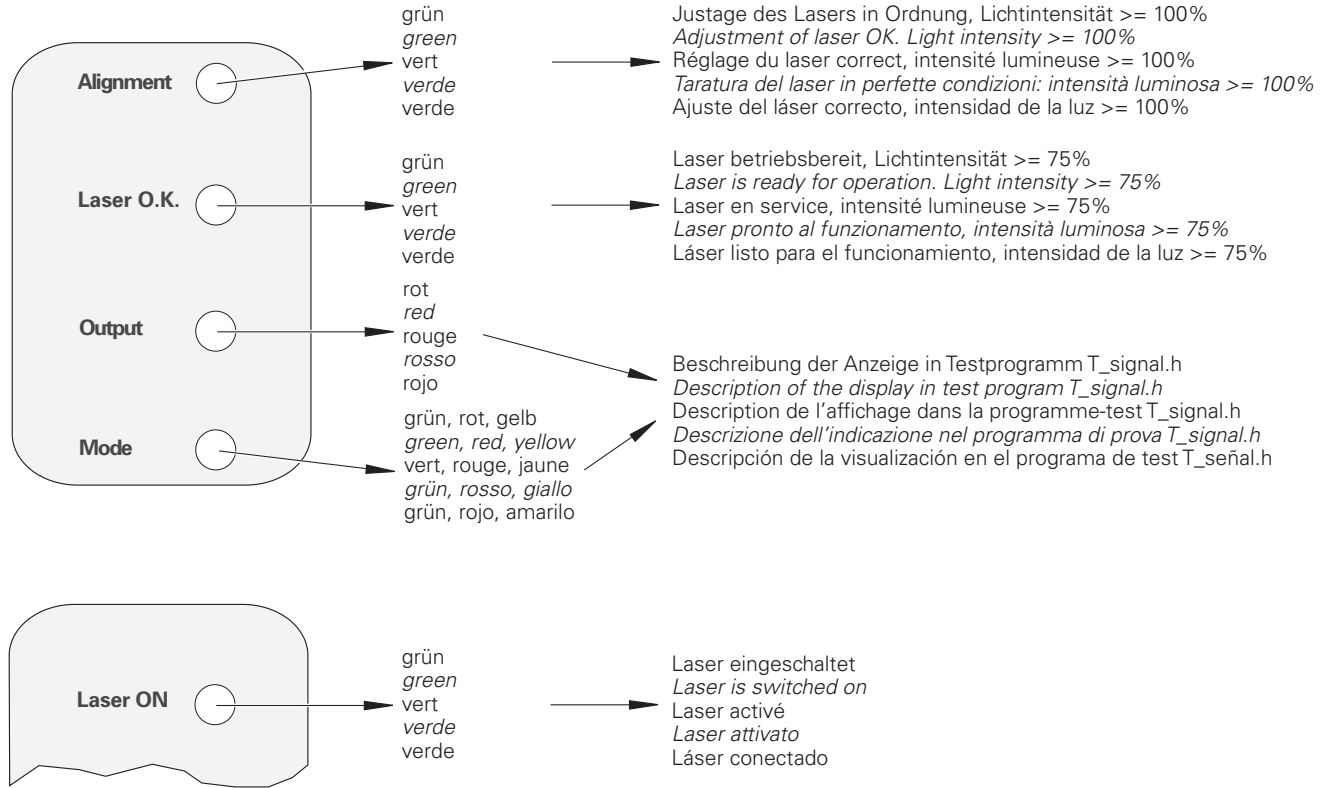

1.



Laser deaktivieren
Deactivate the laser
Désactiver le laser
Disattivare il laser
Desactivar el láser

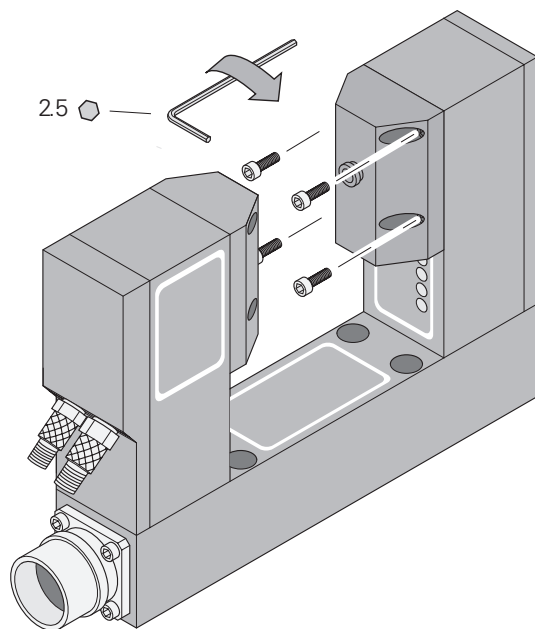

2.

Teile reinigen (empfohlenes Reinigungsspray OKI 2611) und fetten
Clean the parts (recommended cleaning spray: OKI 2611) and lubricate with grease
Nettoyer les pièces (spray nettoyant OKI 2611 recommandé) et les graisser
Pulire i componenti (detergente spray consigliato OKI 2611) e ingrassare
Limpiar las piezas (spray recomendado OKI 2611) y engrasarlas

Fett
Fat
Graisse
Grasso
Engrasante

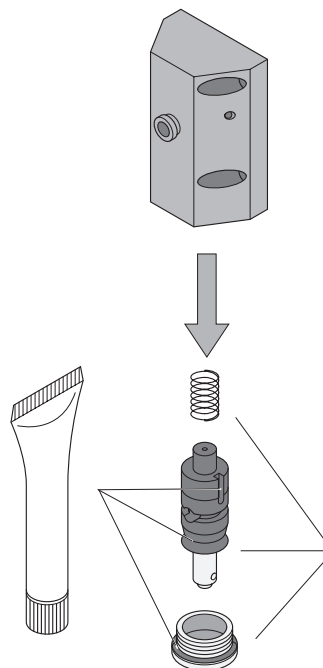

3.

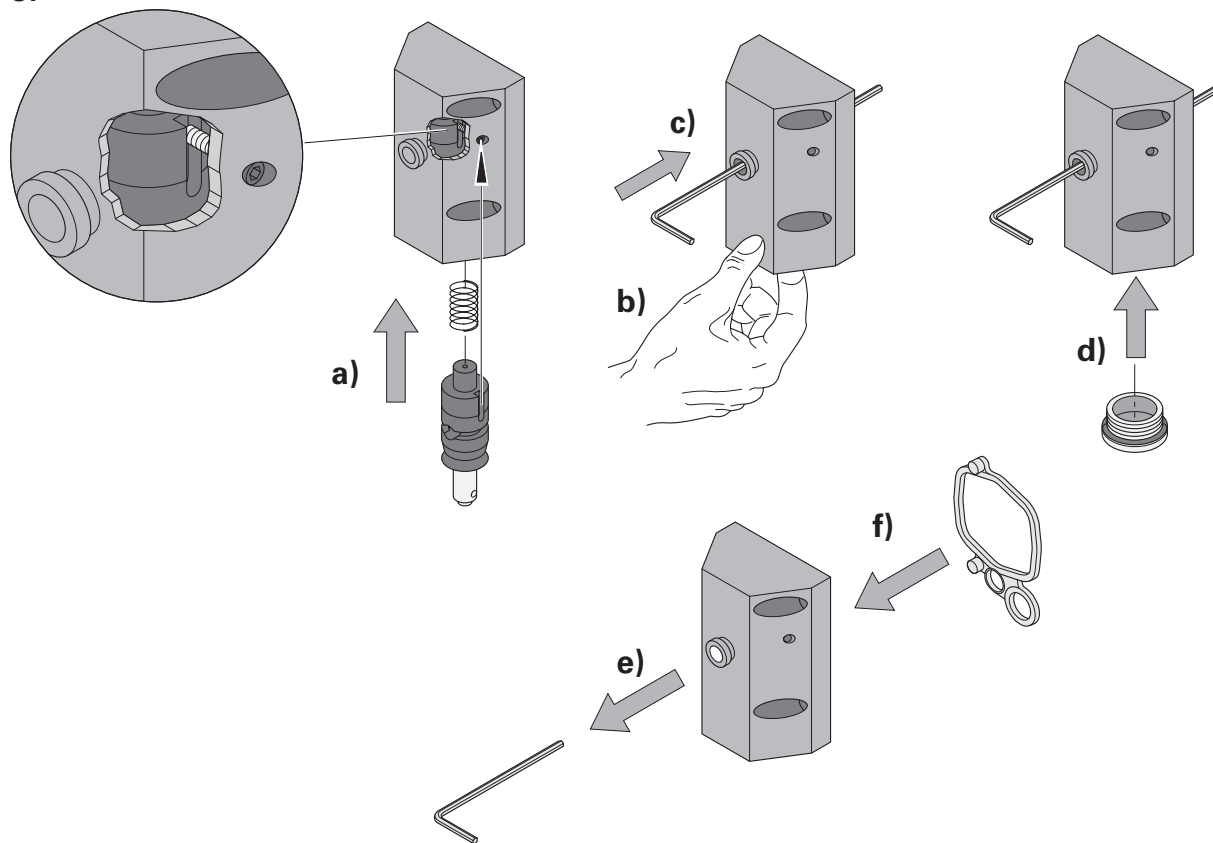

5.

Funktionskontrolle der Schutzblende

Functional check of the contamination shutter

Contrôle du fonctionnement de l'écran de protection

Controllo funzionale del pannello protettivo

Control de funcionamiento del panel de protección

Sichtkontrolle, bei 2 bar muss die Schutzblende öffnen

Visual check. The shutter must open at 2 bar

Contrôle visuel, le cache doit s'ouvrir à 2 bars

Controllo visivo. A 2 bar il parzializzatore si deve aprire

Control visual. El cierre debe abrirse a 2 bar.

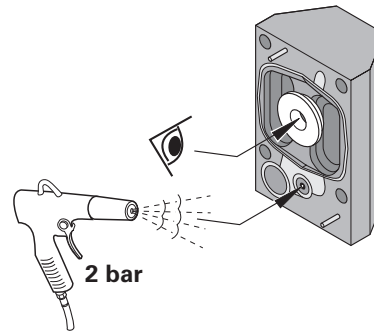

Druckluft! Alle Verschraubungen und Dichtungen prüfen!
Sicherheitsvorschriften beachten!

Compressed air! Check all seals and screw fasteners!

Comply with the safety regulations!

Air comprimé! Vérifier tous les raccords et joints!

fehlt

Aria compressa! Controllare tutti i collegamenti a vite e tutte le guarnizioni!

Attenersi alle norme di sicurezza!

¡Aire comprimido! ¡Comprobar todos los racores y juntas!

¡Tener en cuenta las normas de seguridad!

6.

Wechselseitiges Anziehen der Schrauben beachten!

Remember to tighten the screws crosswise!

Attention au serrage latéral des vis!

Osservare il serraggio alternato delle viti!

¡Tener en cuenta el par de apriete alternativo de los tornillos!

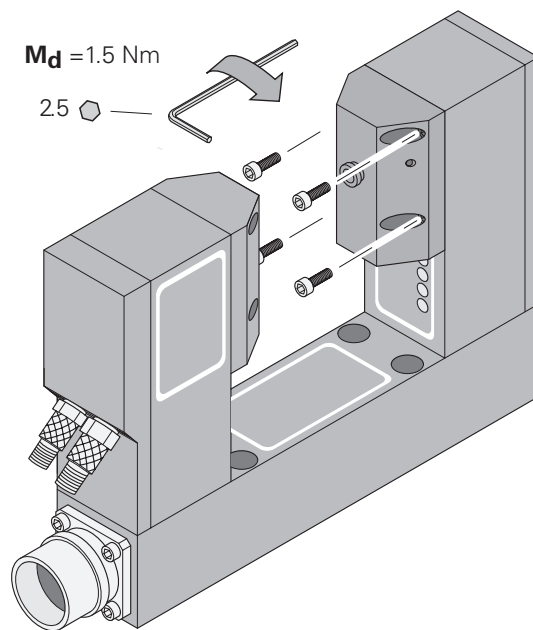

HEIDENHAIN

DR. JOHANNES HEIDENHAIN GmbH

Dr.-Johannes-Heidenhain-Straße 5

83301 Traunreut, Germany

☎ +49 (8669) 31-0

FAX +49 (8669) 50 61

E-Mail: info@heidenhain.de

Technical support FAX +49 (8669) 31-10 00

Measuring systems ☎ +49 (8669) 31-31 04

E-Mail: service.ms-support@heidenhain.de

TNC support ☎ +49 (8669) 31-31 01

E-Mail: service.nc-support@heidenhain.de

NC programming ☎ +49 (8669) 31-31 03

E-Mail: service.nc-pgm@heidenhain.de

PLC programming ☎ +49 (8669) 31-31 02

E-Mail: service.plc@heidenhain.de

Lathe controls ☎ +49 (7 11) 95 28 03-0

E-Mail: service.hsf@heidenhain.de

www.heidenhain.de



Ve 00

581 735-91 · 2 · 5/2006 · H · Printed in Germany

Änderungen vorbehalten · *Subject to change without notice* · Sous réserve de modifications · *Con riserva di modifiche* · Sujeto a modificaciones

